

WINNER

Bomba autoaspirante para piscina
Self priming pump for swimming pools
Pompe auto-aspirante pour piscine

efficiency class

IE3

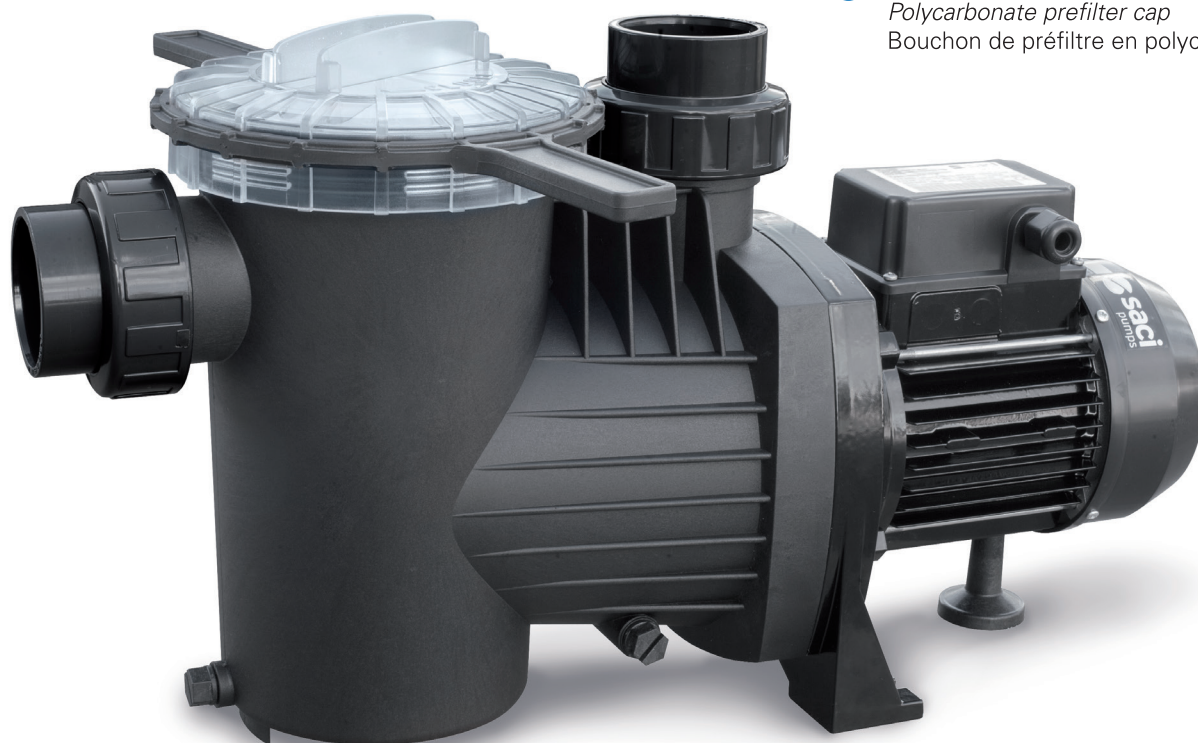

- ✓ **Polipropileno + Fibra de Vidrio**
Polypropylene + Fiberglass
Polypropylène + Fibre de Verre
- ✓ **Eje en acero inoxidable AISI-316**
AISI-316 stainless steel shaft
Manche en acier inoxydable AISI-316
- ✓ **Rodete en Noryl**
Impeller in Noryl
Turbine à Noryl
- ✓ **Sello mecánico en acero inoxidable AISI-316**
Mechanical seal in stainless steel AISI-316
Garniture mécanique en acier inoxydable AISI-316
- ✓ **Tapa prefiltro en policarbonato**
Polycarbonate prefilter cap
Bouchon de préfiltre en polycarbonate



Compatible con SMART POOL
Compatible with SMART POOL

WINNER

Datos embalaje
Packaging data
Données d'emballage

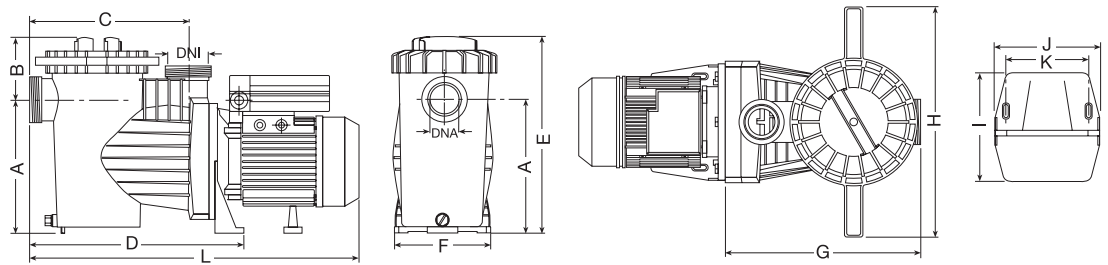
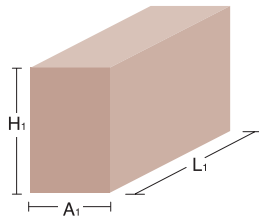

Tipo / Type	A	B	C	D	E	F	G	H	I	J	K	L	L1	A1	H1	DNA DNI	Neto Kg.	Bruto Kg.
WINNER 50	216	109	265	370	325	206	325	400	220	205	160	550	630	230	360	2"	11,7	12,7
WINNER 75	216	109	265	370	325	206	325	400	220	205	160	550	630	230	360	2"	11,5	12,5
WINNER 100	216	109	265	370	325	206	325	400	220	205	160	550	630	230	360	2"	12,9	13,9
WINNER 150	216	109	265	370	325	206	325	400	220	205	160	580	630	230	360	2"	13,9	14,9
WINNER 200	216	109	265	370	325	206	325	400	220	205	160	580	630	230	360	2"	14,9	15,9
WINNER 300	216	109	265	370	325	206	325	400	220	205	160	630	705	230	360	2"	17,4	18,4

Denominación recambios
Spare-part description
Dénomination des pièces

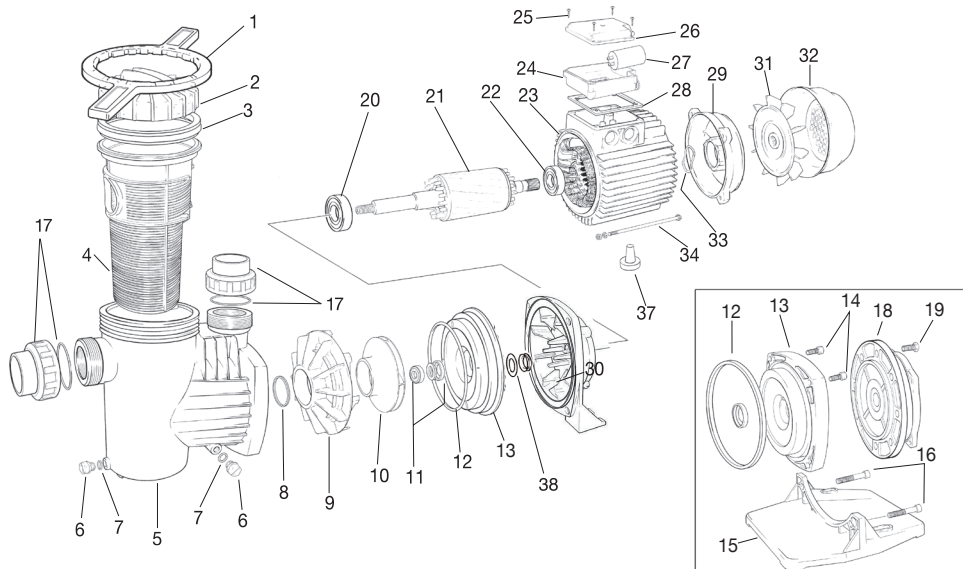

- 1 - LLAVE
- 2 - TAPA PREFILTRO
- 3 - JUNTA PREFILTRO
- 4 - CESTO PREFILTRO
- 5 - CUERPO BOMBA
- 6 - TAPÓN DESAGÜE
- 7 - JUNTA TAPÓN DESAGÜE
- 8 - JUNTA DIFUSOR
- 9 - DIFUSOR
- 10 - TURBINA
- 11 - CIERRE MECÁNICO
- 12 - JUNTA CUERPO BOMBA
- 13 - DISCO PORTASELLO
- 14 - TORNILLO SUPERIOR FIJACIÓN CUERPO BOMBA
- 15 - BASE BOMBA
- 16 - TORNILLO FIJACIÓN BASE
- 17 - KIT RACORES + JUNTAS

- 18 - TAPA DELANTERA MOTOR
- 19 - TORNILLO FIJACIÓN MOTOR
- 20 - RODAMIENTO DELANTERO
- 21 - ROTOR CON EJE
- 22 - RODAMIENTO TRASERO
- 23 - ESTATOR MOTOR + CARCASA
- 24 - CAJA BORNES
- 25 - TORNILLO TAPA CAJA BORNES
- 26 - TAPA CAJA BORNES
- 27 - CONDENSADOR
- 28 - JUNTA CAJA BORNES
- 29 - TAPA TRASERA MOTOR
- 30 - SOPORTE BOMBA
- 31 - VENTILADOR
- 32 - TAPA VENTILADOR
- 33 - ARANDELA LASAJE
- 34 - ESPÁRRAGO MOTOR
- 35 - PIE MOTOR
- 36 - KIT RACORES + JUNTAS
- 37 - TORNILLO FIJACIÓN BASE
- 38 - RETEN DELANTERO IP-55



- 1 - KEY
- 2 - PRE-FILTER COVER
- 3 - PRE-FILTER JOINT
- 4 - PRE-FILTER BASKET
- 5 - PUMP BODY
- 6 - DRAINING PLUG
- 7 - DRAINING PLUG O-RING
- 8 - DIFFUSER JOINT
- 9 - DIFFUSER
- 10 - IMPELLER
- 11 - MECHANICAL SEAL
- 12 - PUMP BODY LID O-RING
- 13 - PUMP BODY LID
- 14 - SUPERIOR PUMP BODY SECURING SCREW
- 15 - PUMP BASE
- 16 - PUMP BASE SECURING SCREW
- 17 - RACORD KIT + JOINTS

- 18 - FRONT MOTOR COVER
- 19 - MOTOR SECURING SCREW
- 20 - FRONT BALL BEARING
- 21 - SHAFT WITH ROTOR
- 22 - BACK BALL BEARING
- 23 - MOTOR CASING
- 24 - TERMINAL BOX
- 25 - TERMINAL BOX SCREW
- 26 - TERMINAL BOX COVER
- 27 - CAPACITOR
- 28 - TERMINAL BOX GASKET
- 29 - BACK MOTOR COVER
- 30 - PUMP SUPPORT
- 31 - FAN
- 32 - FAN COVER
- 33 - THRUST WASHER
- 34 - TIE ROD
- 35 - FOOT MOTOR
- 36 - FRONT IP-55 PROTECTION SEAL



- 1 - CLÉ DU COUVERCLE
- 2 - COUVERCLE PRÉFILTRE
- 3 - JOINT PRÉFILTRE
- 4 - PANIER PRÉFILTRE
- 5 - CORPS POMPE
- 6 - BOUCHON VIDANGE
- 7 - JOINT BOUCHON VIDANGE
- 8 - JOINT DIFUSEUR
- 9 - DIFUSEUR
- 10 - TURBINE
- 11 - FERMETURE MÉCANIQUE
- 12 - JOINT CORPS POMPE
- 13 - COUVERCLE CORPS POMPE
- 14 - VIS SUPÉRIEURE FIXATION CORPS
- 15 - BASE POMPE
- 16 - VIS FIXATION BASE
- 17 - KIT DE RACORDS + JOINTS

- 18 - COUVERCLE AVANT MOTEUR
- 19 - VIS FIXATION MOTEUR
- 20 - ROULEMENT AVANT
- 21 - ROTOR AVEC AXE
- 22 - ROULEMENT ARRIÈRE
- 23 - STATOR MOTEUR + CARCASSE
- 24 - BOÎTE BORNES
- 25 - VIS COUVERCLE BOÎTE BORNES
- 26 - COUVERCLE BOÎTE BORNES
- 27 - CONDENSATEUR
- 28 - JOINT BOÎTE BORNES
- 29 - COUVERCLE ARRIÈRE MOTEUR
- 30 - SUPPORT POMPE
- 31 - VENTILATEUR
- 32 - COUVERCLE VENTILATEUR
- 33 - RONDELLE DE BUTÉE
- 34 - GOUJON FILETÉ MOTEUR
- 35 - PIED MOTEUR
- 36 - JOINT AVANT PROTECTION IP-55